

## Octopus

The new washer-extractors  
and tumble dryers



# The new washer-extractors and tumble dryers

# octoplus®

## Value Added.

### Forever better

Miele is the epitome of quality. For 110 years, Miele has subscribed to a corporate philosophy of being 'forever better', a quality promise that stands for a holistic and systematic approach to laundry care. All Miele products are developed and manufactured to meet the highest of quality standards. The new washer-extractors and tumble dryers make consistent use of innovative technology and clearly underline Miele's role as technological leader. Miele laundry machines offer considerable user benefits with respect to economic operation and reliability. All features strictly comply with the requirements of commercial laundry care.



### Absolutely new

Washer-extractors and tumble dryers with a load capacity of 8 kg represent the ideal size for efficient workflow in many different laundry operations. With its new washer-extractors and tumble dryers, Miele Professional has redefined all existing standards in this category:

#### +volume plus

A capacity that defines its size.

#### +care plus

A system that provides gentle laundry care.

#### +power plus

A performance that offers more.

#### +eco plus

A sustainable, cost effective performance.

#### +flex plus

A process that adapts to all situations.

#### +comfort plus

A simple, user friendly solution.

#### +form plus

A concept that leaves a lasting impression.

#### +brand plus

A strong brand, Made in Germany.

### Multiple awards

The quality and dependability of Miele machines has been confirmed in countless tests. This is no doubt one of the reasons why Miele has been voted best and most trusted brand – as endorsed by numerous awards.



octoplus®



+brandplus  
+powerplus  
+formplus  
+comfortplus  
+careplus  
+flexplus  
+volumeplus



# Washer-extractors and tumble dryers for a wide range of applications.



Washing machine and tumble dryer requirements vary significantly according to target group. Various aspects such as controls, features and programmes play a role.

**However, all target groups have the same requirements regarding:**

- Thorough cleaning
- Gentle treatment of textiles
- Short programme running times

The new Octoplus Miele washer-extractors and tumble dryers meet all these needs in a very special way. Controls are simple, features are commercial-grade and programmes for **all user groups are included as standard.**

The chart shows examples of technical features and specific programmes available as part of the comprehensive response to user needs provided by these washer-extractors and tumble dryers.

Application	Situation/Requirements	Octoplus solution
Contract cleaners	<ul style="list-style-type: none"> <li>• Heavily soiled laundry and items with a tendency to produce lint</li> </ul>	<ul style="list-style-type: none"> <li>• Large dump valve</li> <li>• Cantilever heater elements</li> <li>• Special programmes: Mops, cloths, pads</li> </ul>
Commercial laundries	<ul style="list-style-type: none"> <li>• Various laundry loads and types of textiles</li> </ul>	<ul style="list-style-type: none"> <li>• 72 washing and 42 drying programmes</li> <li>• Controls for 6 dispenser pumps for liquid products</li> <li>• Gas-heated tumble dryers</li> </ul>
Hotels/catering businesses	<ul style="list-style-type: none"> <li>• Thoroughly but gently cleaned textiles for high-end hospitality</li> <li>• Bulky textiles</li> </ul>	<ul style="list-style-type: none"> <li>• Honeycomb drum</li> <li>• Large drum volume</li> <li>• Gas-heated tumble dryers</li> <li>• Special programmes: Bedding, Spa</li> </ul>
Care homes	<ul style="list-style-type: none"> <li>• Short programme running times even in disinfection programmes</li> <li>• Compliance with disinfection temperatures</li> </ul>	<ul style="list-style-type: none"> <li>• Electronic controls and monitoring systems for all programme parameters</li> <li>• Gas heated tumble dryers</li> <li>• Sluice and thermal disinfection programmes</li> <li>• Meets Department of Health guidelines HSG(95)18</li> <li>• Conforms to requirements of The Care Standard Act 2000</li> </ul>
Wet cleaning	<ul style="list-style-type: none"> <li>• Thoroughly but gently cleaned textiles/ outerwear</li> </ul>	<ul style="list-style-type: none"> <li>• Honeycomb drum</li> <li>• Large drum volume</li> <li>• Special programmes: Wet cleaning (Wet-Care) for sensitive outerwear and bedding</li> </ul>



Application	Situation/Requirements	Octopus solution
Housing associations	<ul style="list-style-type: none"> <li>• Short programme cycles for multiple loads per day</li> <li>• Support for users with different linguistic backgrounds</li> </ul>	<ul style="list-style-type: none"> <li>• 21 display languages</li> <li>• Simple to operate</li> </ul>
Small businesses	<ul style="list-style-type: none"> <li>• Simple installation in private households or small businesses</li> <li>• Domestic laundry and heavily soiled workwear (oil, grease, blood)</li> </ul>	<ul style="list-style-type: none"> <li>• Single and three phase options</li> <li>• Domestic and commercial programmes for bakers, butchers, hairdressers/spas</li> </ul>
Self-service laundrettes	<ul style="list-style-type: none"> <li>• Short programme cycles for multiple loads per day</li> <li>• Users with different language backgrounds</li> </ul>	<ul style="list-style-type: none"> <li>• Hot water connection</li> <li>• 21 display languages</li> <li>• Simple to operate</li> <li>• Gas-heated tumble dryers</li> </ul>
Riding stables	<ul style="list-style-type: none"> <li>• Heavily soiled textiles and items with a tendency to produce lint</li> <li>• Bulky horse blankets</li> </ul>	<ul style="list-style-type: none"> <li>• Large dump valve</li> <li>• Cantilever heater elements</li> <li>• Large drum volume</li> <li>• Special programme: Horse blankets</li> </ul>
Spas and beauty centres	<ul style="list-style-type: none"> <li>• Well laundered textiles</li> <li>• Thorough removal of oils, grease and ointments</li> <li>• Soft towels</li> <li>• Short programmes for fast laundry turnaround</li> </ul>	<ul style="list-style-type: none"> <li>• Honeycomb drum</li> <li>• Large drum volume</li> </ul>
Sports clubs	<ul style="list-style-type: none"> <li>• Large laundry loads, in part heavily soiled</li> </ul>	<ul style="list-style-type: none"> <li>• Large drum volume</li> <li>• Dryer basket for sport shoes</li> </ul>
Emergency services	<ul style="list-style-type: none"> <li>• Heavily soiled and in part contaminated clothing</li> <li>• Bulky textiles</li> </ul>	<ul style="list-style-type: none"> <li>• Large drum volume</li> <li>• Honeycomb drum on tumble dryers</li> <li>• Special programmes: Reproofing, breathing masks</li> </ul>

# The new washer-extractors and tumble dryers



## Casing

- Octoblue sides and front
- Lid in Octoblue
- Galvanised rear panel

## Fascia

- Stainless steel



## Casing

- Sides in Octoblue
- Stainless steel front
- Stainless steel lid
- Galvanised rear panel

## Fascia

- Stainless steel



## Casing

- Sides in Octoblue
- Stainless steel front
- Stainless steel lid
- Galvanised rear panel

## Fascia

- Stainless steel

N.B. Please see the Technical Data charts for available colour options.

# Technical data

Washer-extractor	PW 6080 Vario (single phase)	PW 6080 Vario (three phase)	
<b>Design</b>			
Front loader, door aperture [Ø mm]	370	370	
<b>Performance data</b>			
Load capacity 1:10 [kg]	8	8	
Drum volume, HONEYCOMB DRUM <sup>1</sup> [l]	80	80	
Spin speed [max. rpm]	1300	1300	
g-factor	520	520	
Residual moisture [%]	49	49	
<b>Controls</b>			
PROFITRONIC L VARIO	•	•	
Communication module with serial interface	Optional	Optional	
<b>Plumbing</b>			
Cold water, 1/2" with 3/4"- threaded union	1 x	1 x	
Hot water, 1/2" with 3/4"- threaded union	1 x	1 x	
Dump valve DN 70 or drain pump DN 22	•	•	
<b>Motor / electrical connection</b>			
Asynchronous motor with frequency converter	1N AC 230 V 50 Hz	3N AC 400 V 50 Hz	
Heater rating [kW]	5.3	8.0	
Total connected load [kW]	5.5	8.2	
Fuse rating [A]	1 x 30	3 x 16	
<b>Detergent dispensing</b>			
Dispenser drawer in front of machine, 3 compartments	•	•	
<b>Dispensing connections</b>			
Adapter for max. 6 liquid agents	•	•	
<b>Dimensions, weight</b>			
External dimensions H/W/D [mm]	1020/700/727	1020/700/727	
Weight incl. packaging [kg]	140	140	
<b>External finish options</b>			
Sides octoblue <sup>2</sup> , front and lid stainless steel, galvanised rear panel	•	•	
Tumble dryer	PT 7186 Vario Electric (single phase)	PT 7186 Vario Electric (three phase)	PT 7186 Vario Gas (single phase)
<b>Design</b>			
Front loader, door aperture [Ø mm]	440	440	440
Vented drying system	•	•	•
<b>Performance data</b>			
Load capacity 1:22.5 [kg]	8	8	8
Drum volume, HONEYCOMB DRUM <sup>1</sup> [l]	180	180	180
<b>Controls</b>			
PROFITRONIC L VARIO	•	•	•
Communication module with serial interface	Optional	Optional	Optional
Electrical connection	1N AC 230 V 50 Hz	3N AC 400 V 50 Hz	1N AC 230 V 50 Hz
Heater rating [kW]	5.2	7.94	8.0
Total connected load [kW]	5.76	8.5	0.48
Fuse rating [A]	1 x 30 A	3 x 16	1 x 16
<b>Heating</b>			
	Electric	Electric	Gas
<b>Dimensions, weight</b>			
External dimensions H/W/D [mm]	1020/700/727	1020/700/727	1020/700/727
Weight incl. packaging [kg]	88	88	88
<b>External finish options</b>			
Sides and front octoblue <sup>2</sup> , lid octoblue <sup>2</sup> , galvanised rear panel	•	•	•
Sides octoblue <sup>2</sup> , front and lid stainless steel, galvanised rear panel	•	•	•

<sup>1</sup>patented    <sup>2</sup>powder coated    • standard feature    – not available

# Programmes for a wide range of applications



## **Miele programme controls**

Miele's Octoplus-extractors and tumble dryers are controlled by Miele's innovative new PROFITRONIC L VARIO controls. Miele design and manufacture electronic controls in-house for the complete range of Professional washer-extractors and tumble dryers. This process is common to many other components, thereby providing Miele with a flexible approach to design machines tailored to individual requirements. This combines well with the added benefits of complete quality control and total supply chain management.

## **Simple, convenient operation**

All selection steps and programmes are shown in the display in the user's own language. 21 display languages are available. Programme selection is via a rotary selector switch or 4 direct-access pushbuttons.

The washer-extractor offers 72 programmes, the tumble dryer 42. Packages containing special programmes allow users to create their own wash and care programmes. Using pre-configured programme blocks it is possible for example to define the number of rinse cycles or washing and drying temperatures and compile new programmes accordingly.





Programme packages	Washing	Drying
Basic programmes	16	16
Household	2	1
Sportswear	2	-
Hotels	4	5
Bedding	4	4
Disinfection	4	-
Maintenance programme	1	-
Hygiene	1	-
Sluice*	3	-
Bakers/Butchers	6	-
Beauty salons/Health spas	3	-
Contract cleaners*	10	3
Fire service	6	3
Professional cleaners	3	3
Riding stables*	2	2
Special programmes	5	5

\*only available on dump valve models

#### Interfaces, connections

- Optical interface for service diagnosis and programme updates
- 7-pole interface for payment systems
- Communication slot on rear of machine, e.g. for RS 232 interface module
- Remote service with diagnosis, updates and programming via RS 232 interface
- 6 dispensing signals with container empty input signal

# PROFITRONIC L VARIO controls: 3 control sets



Programme selection concept: Standard



Programme selection concept: 4 programmes – 4 buttons



Programme selection concept: Logo

## Individual display design

PROFITRONIC L VARIO controls facilitate 3 programme selection concepts on both washer-extractors and tumble dryers, allowing machines to adapt flexibly to commercial users' needs.

### Programme selection concept: Standard

In 'Standard' mode, the user has access to all programmes from the selected target-group programme packages.

Four programmes can be saved to the direct-access keys for quick selection. Other programmes can be accessed by selecting 'Further programmes'. Temperatures, spin speeds, a pre-wash and the delay-start facility (max. 24 h) can be changed individually for each programme.

This approach is ideally suited to a wide range of applications in hotels and restaurants, care homes, commercial laundries and dry-cleaning businesses.

### Programme selection concept: 4 programmes – 4 buttons

This concept selects 4 programmes from the full range and saves them to the fast-access pushbuttons. The user cannot make any changes.

This approach offers maximum security and is ideal for self-service laundrettes or for running disinfection programmes with defined temperatures.

### Programme selection concept: Logo

In 'Logo' mode, the laundry operator selects 12 programmes to be made available to users. The first 3 are visible in the display and can be selected using direct-access buttons 1–3. The fourth button calls up a list containing 9 further programmes.

This blend of simple operation and a wide range of programmes is ideal, for example, for housing associations or student accommodation and campsites, etc. Operators can even submit their own logo for inclusion in the display.



Programme selection concept: Logo – Residual moisture



Programme selection concept: Logo – Time



The 'Logo' mode offers further options on the tumble dryer.

**Programme selection concept:  
Logo – Residual moisture**

As on the washer-extractor, the main programmes are assigned to buttons 1–3 by the operator. Button 4 is used to call up further programmes.

**Programme selection concept:  
Logo – Time**

In 'Logo – Time' mode, the user can select from 4 temperature settings. The required time is selected using the rotary selector switch.

# The new PW 6080 Vario washer-extractor

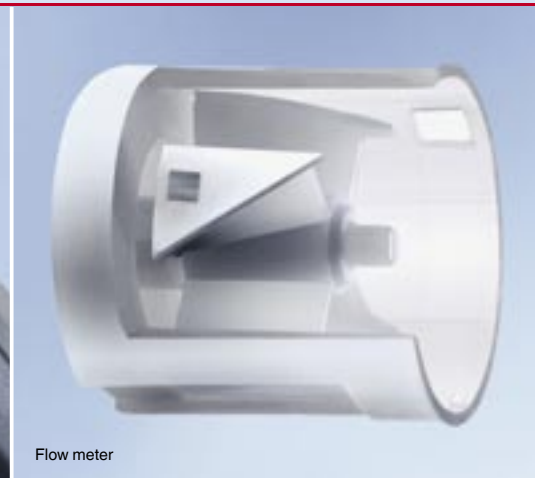

Flow meter



## Size and performance

As with motorcars, technical specifications form the basis for product comparisons.

- Both the 80-litre washer-extractor drum and the 180-litre dryer drum offer ample space for an 8 kg load and the right conditions for thorough, gentle and fast laundry care
- A 1300 rpm final spin achieves a residual moisture content of only 49%
- Drum diameter and spin speed combined achieve a g-factor of 520
- 3 heater elements with an 8 kW heater rating enable programme cycles as short as only 53 mins. (Cottons 60°C, Cold/hot water connection, 400 V version)

## Unique gentle fabric care

Gentle treatment of fabrics in Miele's patented honeycomb drum has been endorsed by scientific evidence provided by the Institute for Applied Research in Krefeld, Germany:

- Textiles are washed much more gently
- Stability of shape and longer life cycle through gentle treatment
- The woollens programme is as gentle as washing by hand



## Economical and environmental aspects

Miele laundry machines have always set standards in all load-size categories with respect to low consumption and fast programme cycles. These new washer-extractors now take cost-efficiency and environmental concerns one step further:

- 16% lower energy consumption<sup>1</sup>
- 30% lower water consumption<sup>1</sup>
- 11% shorter programme cycles<sup>1</sup>
- 16% higher g-factor and 5% lower residual moisture<sup>1</sup>

## Miele quality – 'Made in Germany'

- Robust and torsion-resistant spaceframe construction
- Removable front, rear and side panels guarantee excellent service accessibility, even when machines are installed side by side
- 4 springs, commercial-grade shock absorbers and cast-iron counterweights stabilise the suspended suds container assembly, ensuring smooth running properties even at high speeds
- Stainless-steel drum, drum flange and suds container, resistant to wash liquor and disinfectants

<sup>1</sup> Compared to Miele's WS 5073 washing machine (7.5 kg load capacity) and Miele's PW 6080 washer-extractor (8 kg load capacity) in Cottons 60°C programme, cold water fill



## **Commercial specifications, professional solution**

Miele makes efficient processes and perfect laundry care available to all target groups. Numerous innovations and patented solutions originate in Miele's own research and development division.

- The unstressed, suspended and gaiterless suds container assembly guarantees optimum laundry care, even when processing large loads
- Large drum volume for simple loading and fast wetting of laundry
- Powerful heater elements with 8 kW rating (400 V version)
- The 3 heater elements are positioned in the suds container in such a way as to ensure the free passage of water and to avoid any blockage of the drainage system.
- Approved to comply with recent EU machine legislation and designed specifically for commercial use

## **Water intake, drainage**

- Flexible use of hot and cold water
- A flowmeter monitors water intake precisely and helps conserve water
- Pressure sensors determine water levels to reflect the load size
- A powerful drain pump (24 l/min throughput capacity at 1 m head height) allows great installation flexibility
- Alternatively, a virtually maintenance-free dump valve (70 mm diameter) is the ideal option when faced with coarse soiling

## **Pre-wash, main wash, disinfection wash**

- Connection at rear of machine for delivery of up to 6 liquid products
- Fail-safe liquid detergent supply
- Separate intake paths thanks to patented intake duct to avoid unintentional mixing of liquid chemical agents

## **Washing, rinsing, spinning**

Laundry care requires a perfect blend of thorough cleaning, gentle mechanical action and efficiency.

- Target group programmes with finely tuned wash parameters – tested in both laboratory and field trials
- Smooth running properties thanks to two-stage imbalance monitoring during run-up to spin speed
- Thorough rinse results and reduced water consumption through 2 rinse cycles with rinse-spin followed by high-speed final spin

# The new PT 7186 Vario tumble dryer



## Individually or as a pair

The new Miele PT 7186 Vario dryer vouches for perfect laundry finish and ideally complements the new PW 6080 Vario washer-extractor. The casing subscribes to the same quality standards as the washer-extractor.

## Size and performance

- Load capacity 8 kg, drum volume 180 l
- Heater rating 8 kW (400 V version)
- Air throughput 310 m<sup>3</sup>/h
- Programme duration 39 mins. (reduction in residual moisture from 55% to 0%)

## Economical and environmental aspects

Miele dryers are renowned for their efficiency. With the new OctoPlus dryers, Miele has now taken efficiency onto the next level:

- 16% lower energy consumption<sup>1</sup>
- 11% shorter programme cycles<sup>1</sup>

## Hard-working and good-looking

Miele machines have a history of winning international design awards. The latest award winner is the new PT 7186 Vario tumble dryer. Proof enough that proverbial quality, optimum functionality and high-end product design can be brought together to form a perfect product.



product  
design  
award

2009 ■

## PerfectDry

Different textiles require different residual moisture levels at the end of a drying cycle, depending on whether they are hung straight away in a wardrobe, hand-ironed or processed in a rotary ironer. PerfectDry – Miele's patented residual moisture sensing system uses sensors to precisely measure and monitor the degree of drying.

## Unique gentle fabric care

Only Miele laundry machines can offer the gentle fabric care afforded by the patented honeycomb drum. The honeycomb drum is able to give very delicate fabrics the treatment they deserve. Textiles retain their good looks longer. Investments in new textiles remain low.

In the dryer, the sculptured hexagonal pattern on the drum and the SoftLift ribs lift laundry high and cushion items gently on pockets of air as they fall. Diagonal air flow in the drum prolongs the contact time with laundry, resulting in intensive and uniform drying, a technology that guarantees short drying times and lower energy consumption.

<sup>1</sup>Comparison of Miele's T 6185 tumble dryer (7.5 kg load capacity) and Miele's PT 7186 dryer (8 kg load capacity) in 'Normal dry' programme



## Commercial specifications, professional solutions

- 420 mm porthole for simple loading of bulky items such as bedding
- 2 separate motors for drive and fan ensure a constant air stream and even drying, even during reversing cycles
- Symmetrical reversing rhythm with rotational speed of 48 rpm for perfect laundry care and even drying
- Large-surface filter with an area of 1406 cm<sup>2</sup> to capture the lint from up to 16 drying cycles

## Electricity or gas, that is the question!

The new Miele PT 7186 Vario dryer is available optionally with electric or gas heating. If on-site conditions allow a machine to be connected to the gas supply, this is by far the most cost-effective and environmentally friendly option. The increased outlay for a gas-heated tumble dryer is capitalised within a very short period of time.

The machine's green footprint is also impressive. Natural gas burns virtually particle-free, emitting up to 50% less CO<sub>2</sub> than a comparable electrically heated machine. As natural gas is a prime source of energy, there are no conversion losses.<sup>3)</sup>

- Open plinth, Octoblue
- Box plinth, stainless steel
- Plinth with drawer, stainless-steel front, Octoblue sides

Dryer basket

For sports shoes, soft toys or delicate silks

Mask brace (not illustrated)

To secure 4 breathing masks

<sup>3)</sup> Comparison published by BDEW (German association of utilities and water boards) entitled 'Natural gas in laundries and dry-cleaning businesses', <http://www.gewerbegas-online.de>

## Accessories

Plinths H 30 cm

Miele Co. Ltd, Fairacres  
Marcham Road, Abingdon  
Oxon OX14 1TW

Tel: + 44 (0) 845 365 0555  
Fax: + 44 (0) 845 365 0777

www.miele-professional.co.uk  
info@miele.co.uk

## Miele worldwide:

### AUSTRALIA

Miele Australia Pty. Ltd.  
1 Gilbert Park Drive  
Knoxfield, VIC, 3180  
Tel. +61(0)3/97 64 71 30  
Telefax +61(0)3/97 64 71 49

### AUSTRIA

Miele Gesellschaft mbH.  
Mielestraße 1  
5071 Wals/Salzburg  
Tel. +43(0)50 800-81 481  
Telefax +43(0)50 800-81 429

### BELGIUM

N.V. Miele S.A.  
z.5 Mollem 480  
Hof te Bollebeeklaan 9  
1730 Mollem  
Tel. +32(0)2/451 14 11  
Telefax +32(0)2/451 14 14

### CANADA

Miele Limited  
161 Four Valley Drive  
Vaughan, ON L4K 4V8  
Tel. (905) 660-9936  
Telefax (905) 532-2290

### CHILE

Miele Ltda.  
Av. Vitacura 3285  
Vitacura  
Santiago de Chile  
Tel. +56 2 798-9000  
Telefax +56 2 798-9049

### CHINA

Miele Beijing Rep. Office  
3W Suite 512, Oriental Plaza,  
1 East Chang An Avenue  
Dong Cheng District  
Beijing 100738, P.R. China  
Tel. +86 10 85151919  
Telefax +86 10 85181797

### Miele Shanghai

Suite 1102, United Plaza  
1468 Nanjing Road West  
200040 Shanghai, P.R. China  
Tel. +86 21 62884200  
Telefax +86 21 62884100

### CROATIA

Miele d.o.o.  
Buzinski prilaz 32  
10000 Zagreb  
Tel. +385/1/66 89 000  
Telefax +385/1/66 89 090

### CZECH REPUBLIC

Miele spol. s.r.o.  
Hněvkovského 81B  
61700 Brno  
Tel. +420(0)5 4 35 53-1 11  
Telefax +420(0)5 4 35 53-1 19

### DENMARK

Miele A/S  
2600 Glostrup, Erhvervsvej 2  
Tel. +45 43 27 11 00  
Tel. Salg/Professional  
+45 43 27 15 00  
Tel. Jylland +45 97 12 70 66  
Telefax hovednr. +45 43 27 11 09  
Telefax Salg/Professional  
+45 43 27 15 09

### FINLAND

Miele Oy  
Porttikaari 6  
01200 Vantaa  
Tel. +358(0)9 87 59 70  
Telefax +358(0)9 87 59 72 99

### FRANCE

Miele S.A.S.  
9 avenue Albert Einstein  
93151-Le Blanc-Mesnil (Paris)  
Tel. +33(0)1/49 39 34 44  
Telefax +33(0)1/49 39 34 38

### GERMANY

Miele & Cie. KG  
Carl-Miele-Straße 29  
33332 Gütersloh  
Tel. 0 180 220 21 21 (6 ct)\*  
Telefax 0 800 225 57 55  
\*Only in Germany

### GREAT BRITAIN

Miele Co. Ltd.  
Fairacres  
Marcham Road, Abingdon  
Oxon OX14 1TW  
Tel. +44 (0)845 365 0555  
Telefax +44 (0)845 365 0777

### GREECE

Miele Hellas E.P.E.  
Mesogion 257  
154 51 N. Psychiko-Athen  
Tel. national 01/10 6 79 44 44  
international 00 30/2/10 6 79 44 44  
Telefax 01/10 6 79 42 09  
international 00 30/2/10 6 79 42 09

### HUNGARY

Miele Kft.  
Alsó Törökvezs út 2.  
1022 Budapest  
Tel. +36 (06) 1 8806-400  
Telefax +36 (0) 1 8006-402

### HONG KONG

Miele Hong Kong Ltd.  
AIA Plaza, Room 24th Floor,  
18 Hysan Avenue,  
Causeway Bay, Hong Kong  
Tel. +852/26101331  
Telefax +852/28901266

### INDIA

Miele Appliances India Pvt. Ltd.  
Ground Floor,  
Copia Corporate Suites,  
Commercial Plot No. 9, Jasola,  
New Delhi - 110025  
Tel. +91 (0)11 469000-00  
Telefax +91 (0)11 469000-01

### IRELAND

Miele Ireland Ltd.  
2024 Bianconi Avenue  
Citywest Business Campus  
Tel. +353(0)1/461 07 10  
Telefax +353(0)1/461 07-97

### ITALY

Miele Italia S.r.l.  
Strada di Circonvallazione, 27  
39057 S. Michele-Appiano (BZ)  
Tel. +39 04 71/66 61 11  
Telefax +39 04 71/66 63 50

### JAPAN

Miele Japan Corp.  
E Space Tower 11F  
3-6 Maruyamacho  
Shibuya-ku Tokyo  
150-0044 Japan  
Tel. +81(3)5784-0030  
Telefax +81(3)5784-0035

### KAZAKHSTAN

Miele LLP  
Building 1B (office 602)  
Al-Farabi Pr. 13  
050059 Almaty  
Tel. +7 727 3111141  
Telefax +7 727 3111042

### KOREA

Miele Korea Limited  
Miele Haus, 607-10 Yeoksam-dong  
Gangnam-gu  
Seoul 135-080  
Tel. +82 2 3451 9353  
Telefax +82 2 3451 9399

### LATVIA

Miele SIA  
Kr. Valdemāra 21-621  
1010 RIGA  
Tel. +371 6 7035232  
Telefax +371 6 7035252

### LUXEMBOURG

Miele s.à r.l.  
20, Rue Christophe Plantin  
2339 Luxembourg  
Tel. +352/4 97 11-25  
Telefax +352/4 97 11-39

### MEXICO

Miele S.A. de C.V.  
Av. Santa Fé 170  
German Centre 0-4-2  
Col. Lomas de Santa Fé  
C.P. 01210 México, D.F.  
Tel. +52/55 85 03 98 70  
Telefax +52/55 85 03 98 74

### NETHERLANDS

Miele Nederland B.V.  
De Limiet 2  
4131 NR Vianen  
Tel. +31(0)3 47/37 88 83  
Telefax +31(0)3 47/37 84 29

### NEW ZEALAND

Miele New Zealand Ltd.  
Unit L, 10-20 Sylvia Park Road  
Mt. Wellington, 1060 Auckland  
Tel. +64(0)9/573 1269  
Telefax +64(0)9/573 1268

### NORWAY

Miele AS  
Loxaveien 13  
1351 Rud  
Tel. +47/67 17 31 00  
Telefax +47/67 17 31 10

### POLAND

Miele Sp. z. o. o.  
ul. Gotarda 9  
02-683 Warszawa  
Tel. +48/022/5 48 40 00  
Telefax +48/022/5 48 40 10

### PORTUGAL

Miele Portuguesa, Lda.  
Av. do Forte, 5  
2790-073 Carnaxide  
Tel. +351/21/42 48-100  
Telefax +351/21/42 48-109

### ROMANIA

Miele Appliances SRL  
Intrarea Narciselor 8  
OTOPENI  
Jud. Ilfov  
Tel. +40 21 3520777  
Telefax +40 21 3520776

### RUSSIA

000 Miele CIS  
Leningradsky Prospekt, 39A  
125167 Moscow  
Tel. +7(8)495 745-8992  
Telefax +7(8)495 745-8680

### SERBIA

Miele d.o.o. Beograd  
Palmoticeva 16A  
BEOGRAD - Stari Grad 11000

### SINGAPORE

Miele Pte. Ltd.  
163 Penang Road #04-02/03  
Winsland House II  
Singapore 238463  
Tel. +65/67 35 11 91  
Telefax +65/67 35 11 61

### SLOVAKIA

Miele spol. s. r. o.  
Plynárenská 1  
82109 Bratislava  
Tel. +421/2/58 10 31 11  
Telefax +421/2/58 10 31 19

### SLOVENIA

Miele d.o.o.  
Brncičeva 41 g  
1000 Ljubjana  
Tel. +386 (0)1563 44-80  
Telefax +386 (0) 1563 44-90

### SOUTH AFRICA

Miele SA (Pty) Ltd.  
63 Peter Place  
Bryanston 2194  
Tel. +27(0)11/5 48-19 00  
Telefax +27(0)11/5 48-19 35

### SPAIN

Miele S.A.U.  
Carretera de Fuencarral, 20  
28108 Alcobendas (Madrid)  
Tel. +34/91/6 23 20 00  
Telefax +34/91/6 62 02 66

### SWEDEN

Miele AB  
Industrivägen 20  
Box 1397  
171 27 Solna  
Tel. +46(0)8/5 62 29-000  
Telefax +46(0)8/5 62 29-209

### SWITZERLAND

Miele AG  
Limmatstr. 4  
8957 Spreitenbach  
Tel. +41(0)56/4 17 20 00  
Telefax +41(0)56/4 17-24 69

### TURKEY

Miele Elektrikli Aletler  
Diş. Tic. ve Paz. Ltd. Şti.  
Güvercin Sokak No. 10  
34330 Levent-Istanbul  
Tel. +90/2 12/3 86-08 00  
Telefax +90/2 12/3 25 84 49

### UKRAINE

Miele LLC  
Zhylyanskaya Str. 48, 50 A  
01033 Kiev  
Tel. +38 (8)044 4960300  
Telefax +38 (8)044 4942285

### UNITED ARAB EMIRATES

Miele Appliances Ltd.  
Gold & Diamond Park  
Sheikh Zayed Road  
Building No. 6,  
Offices Nos. 214-220  
Dubai  
Tel. +971 4 3418444  
Telefax +971 4 3418852

### USA

Miele, Inc.  
9 Independence Way  
Princeton, NJ 08540  
Tel. 001-800/843 72 31  
Telefax 001-609/419 42 41

### OTHER COUNTRIES:

Sales International  
Miele & Cie. KG  
Carl-Miele-Straße 29  
33332 Gütersloh  
Tel. +49(0)52 41-89 15 07  
Telefax +49(0)52 41-89 15 00